

TECHNICAL SPECIFICATIONS TATA SK 407 Ex/31 BS4

**POWERTRAIN**

Engine Type	TATA 4SP CR BS4 Turbo Inter-cooled
Displacement	2 956 cc
Max. Power Output	62.5 kW @ 2 800 r/min
Max. Torque	250 Nm @ 1 400 - 2 400 r/min
Bore x Stroke	97 mm x 100 mm
Clutch	Dry, Single Plate - 280 mm dia
Transmission	GBS27 Fully Synchronesh, 5 Forward + 1 Reverse (with PTO)

**FUEL SYSTEM**

Fuel Injection System	Electronic Delphi
Fuel Tank Capacity	60 l

**ELECTRICALS**

Battery	12 V, 75 Ah
---------	-------------

**PERFORMANCE**

Gradeability	32.41 %
Max. Speed in Top Gear	93 km/h

**STEERING**

Steering System	Integral Hydraulic Assisted Power Steering
-----------------	--

**FRAME**

Frame	Ladder Type Frame with Riveted/Bolted Cross Members - Thickness - 5 mm
-------	--

**BRAKES**

Service Brake	Dual Circuit Hydraulic with Tandem Master Cylinder
Parking Brake	Cable Operated Mechanical

**SUSPENSION & TYRES**

Front Suspension	Semi-elliptical Leaf Springs, Rear: Semi-elliptical Leaf Springs + Additional Auxiliary Springs
------------------	---

Rear Suspension

Semi-elliptical Leaf Spring and Hydraulic Double Acting Telescopic Type Shock Absorber - Additional Auxiliary Springs

No. of Tyres

Front - 2, Rear - 2, Spare - 1

Front

Cross Ply with Tube 7.50 - 16 - 16 PR

Rear

Cross Ply with Tube 7.50 - 16 - 16 PR



**Tipper Chassis with Cab & Load Body**

1 850 kg

4 400 kg

6 250 kg



**Tipper Chassis with Cab & w/o Load Body**

1 850 kg

4 400 kg

6 250 kg

**WEIGHT**

Front Axle Weight - FAW

Rear Axle Weight - RAW

Gross Vehicle Weight

**OVERALL DIMENSIONS**

Wheelbase

Length

Height

Width

**LOAD BODY DIMENSIONS**

Length

Width

Side Deck Height

Min. Turning Radius

Min. Ground Clearance

Warranty

3 100 mm

5 120 mm

2 257 mm

2 055 mm

2 870 mm

1 870 mm

500 mm

11 000 mm

210 mm

3-year or 3 lakh km (Whichever is earlier)

3 100 mm

4 960 mm

2 257 mm

2 055 mm

NA

NA

NA

11 000 mm

210 mm

Specifications are subject to change without prior notice. These are indicative photos, specifications for reference only.

**Ex2 Delighters:** Digital Clock, Portable & Clear Lens Lamp, Shirt Hook, Mobile Charger, Rear View Mirror, Utility Box & Reverse Beeper

**TATA MOTORS**  
Connecting Aspirations

**POWERFUL PERFORMANCE IN EXTREME CONDITIONS**

**SK 407**



**EX**

has become synonymous with high performance and superior quality



- **EXTRA REVENUE**
- **EXTRA SAVINGS**
- **EXTRA PROFITS**
- **EXTRA COMFORT**
- **EXTRA SAFETY**

Dealer Stamp

For more information, please visit our website: [www.light-trucks.tatamotors.com](http://www.light-trucks.tatamotors.com)  
You can also contact our Sales Office: Tata Motors Limited, 4th Floor, Ahura Centre, 82, Mahakali Caves Road, MIDC, Andheri (East), Mumbai - 400 093 or call toll-free no. **1800 209 7979**.

*Terms & Conditions apply as per the policy of ITGI. Insurance available on light, intermediate & heavy commercial vehicles.  
CAUTION: Accessories shown in the picture or elsewhere do not constitute standard fitment. The specifications are merely indicative.  
Due to continuous product improvements, these specifications are liable to change without notice.*



## India's Iconic LCVs

The right choice for the Indian market

### SK 407 TIPPER

India's quarry specialist, rightly named as the only light truck with a 62.5 kW power & 250 Nm of torque, giving it the ability to mount any gradient and rule any road. The SK 407 Tipper is exceptionally powerful and stable while carrying extreme load.

### SFC: ADVANTAGE

#### SAFE & COMFORTABLE

We understand that driving commercial vehicles is a serious business. For special applications where often speed is of the essence, the customer needs to know that he will be safe at all times. The unique 'nose' of the SFC 407 gives confidence, safety and security to the person behind the wheels.

Tata Motors is the only manufacturer in the country actively selling SFC face vehicles in the Light Commercial Vehicle segment. At Tata Motors, we believe that safety is our number one priority.

### SALIENT FEATURES

- Reclining and sliding driver seats
- Door handle cum armrest
- Bottle holder
- Seating capacity - Driver + 2
- Seat material - Vinyl fabric
- Engine compartment light
- Seat belt warning light for driver
- Moulded roof lining
- ELR seat belt
- Glove box
- Roll down window
- Adjustable head rest
- Utility box under drivers seat
- Strongest & reinforced ladder type chassis frame
- Battery charge indication lamp
- Engine oil low pressure indicator light
- Provision for power take off (Mechanical)
- High gradeability - 32 % and excellent stability in off-road conditions
- 3 additional leaf springs for better off-roading
- Height adjustable seat

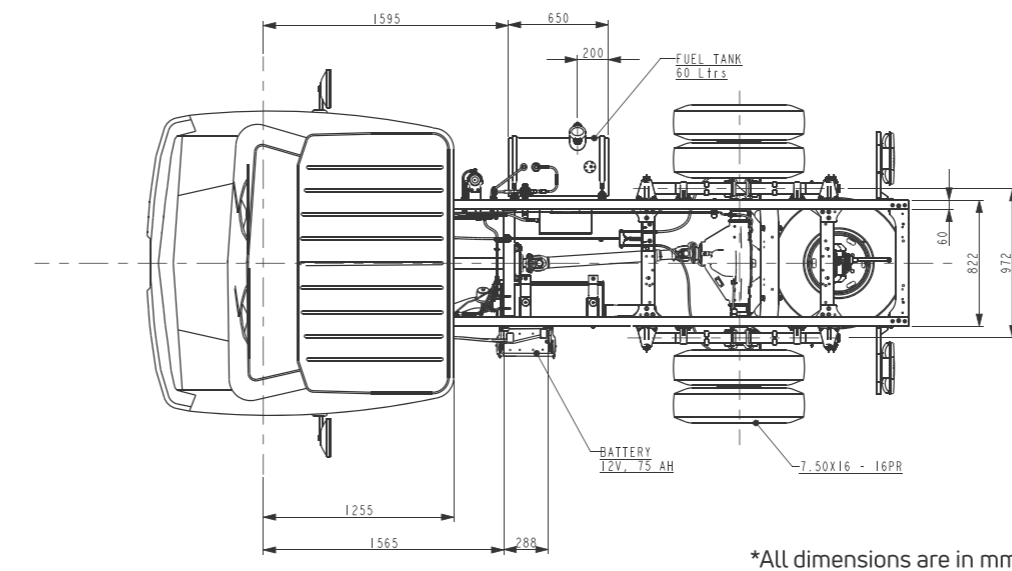
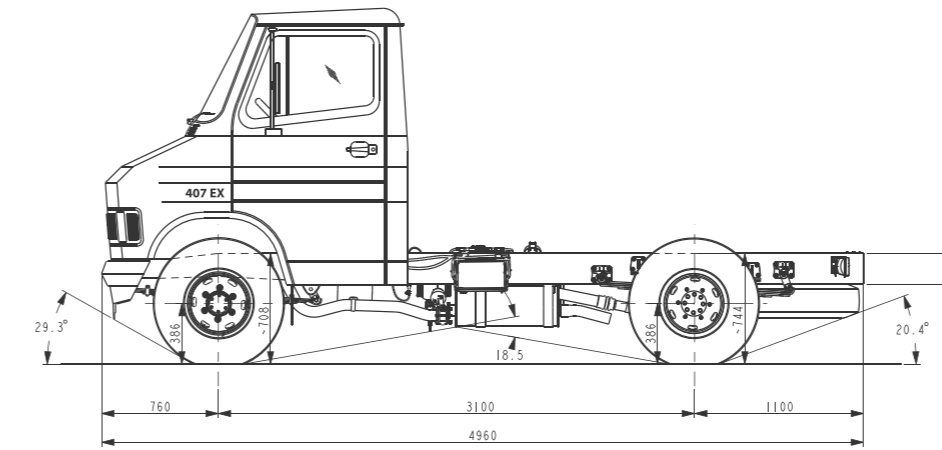

\*All dimensions are in mm

### MOST FUEL EFFICIENT ENGINE

#### TATA 4SP CR TURBO INTER-COOLED

- Reliable 4SP CR Engine with 62.5 kW
- Power and 250 Nm Torque Optimised for Best-in-class Power and Mileage
- Largest Clutch Plate (280 mm) in Segment
- BS4 Compliant



### TRIED, TESTED & TRUSTED

- Reliable 4SP CR engine
- High horsepower and torque
- Heavy duty aggregates
- Lowest spare parts cost
- Most cost efficient in its class
- Highest resale value
- Largest customer base

### ALL-SEASON MANY APPLICATIONS



Laterite



Sand



Bricks



Heavy Duty



Gravels



Cement



9 + 3 - ADDITIONAL LEAF SPRINGS



POWER STEERING



REINFORCED CHASSIS FRAME



SEMI-FORWARD CAB DESIGN